

प्रौद्योगिकी की स्थानांतरण के लिए पसंदकी अभिव्यक्ति

EXPRESSION OF INTEREST for TRANSFER OF TECHNOLOGY

“ 1.5 kW Wireless Charger for Light Electric Vehicles”



प्रगतसंगणन विकास केंद्र
(इलेक्ट्रॉनिकी और सूचना प्रौद्योगिकी मंत्रालय, भारत सरकार)
तिरुवनंतपुरम, केरल 695033
द्वारा जारी।

टेलीफोन: 098470 69184 फैक्स: 0471 2723456 ईमेल: tpc@cdac.in
वेबसाइट: www.cdac.in

Issued by

CENTRE FOR DEVELOPMENT OF ADVANCED COMPUTING

(The Premier R&D organization of the Ministry of Electronics and Information Technology (MeitY), Govt. of India)

Thiruvananthapuram, Kerala, 695033

Phone: 098470 69184/04712723333(450) Fax: 0471 2723456 Email: tpc@cdac.in

Website: www.cdac.in

Published on 15 /12/2023

Table of Contents

SL No.	Section	Page No.
1	Introduction	3
2	Brief about C-DAC	3
3	Brief description about the technology to be transferred	3
4	Know how involved in the ToT	5
5	Advantages of Wireless Charger:	5
6	Applications of Wireless Charger based systems:	6
7	Invitation for Expression of Interest	6
8	Who can Apply	7
9	How to Apply	7
10	TOT Agreement	7
11	Validity & Renewal of TOT agreement	8
12	C-DAC Deliverables	8
13	Training for TOT Partners	9
14	Field implementation support	9
15	Direct implementation by C-DAC	10
16	Maximum List Price/GeM Price	10
17	Annexure-I (Part A & Part B) –(2 pages)	11
18	Annexure – II (Financial Bid Format)	12
19	Annexure – III (Product Brochure)	13

1. Introduction

Centre for Development of Advanced Computing (C-DAC) invites “**Expression of Interest**” (EOI) from Indian companies for transfer of technology (ToT) from C-DAC to manufacture, market, sell and deploy **Wireless Charger for light electric vehicles**, which can replace the high frequency conventional magnetic components.

This document gives details about

- The product
- The terms and conditions for companies to propose their Expression of Interest and
- How to enter into Transfer of Technology (ToT) agreement based on the terms given herein.

2. Brief about C-DAC

Centre for Development of Advanced Computing (C-DAC) is the premier R&D organization of the Ministry of Electronics and Information Technology (MeitY), Govt. of India for carrying out R&D in IT, Electronics and associated areas. It is a national Centre of Excellence, pioneering application-oriented research, design and development in Electronics and Information Technology.

The Centre has contributed significantly to the growth of the industry in general and the electronics sector in particular through the indigenous development of commercially viable systems and products, foreign technology absorption, adaptation and upgrades, consultancy and training and turnkey implementation of contract projects. The Centre has several firsts to its credits and is the recipient of prestigious national level awards for excellence in application- oriented R & D.

The Mission mode programmes of C-DAC include High performance computing, grid and cloud computing, Multilingual computing & Heritage Computing, Professional Electronics, VLSI and Embedded systems, Software technologies, Cyber Security & Cyber Forensics, Health Informatics, Intelligent Transportation Systems and others.

3. Brief description about the technology to be transferred



Wireless charging is a solution with flexibility to charge an Electric Vehicle where we don't need to have wired connection between charging point and vehicle. Wireless charging can be of two types: one, stationary charging where vehicle remains stationary/standing and second, charging while in motion where vehicle keeps on moving and gets charged. A typical wireless charging system consist of power electronics system to receive energy from grid point (single/three phase), coil system to transfer energy from the grid point to the vehicle through high-frequency inductive coupling and on-board power electronics to charge the on-board batteries. In a wireless charger one coil remains buried in the ground and another coil is fixed at the bottom of the vehicle. When the two coils come in the vicinity, charging of the vehicle starts.

A typical wireless charger system consists of sub-systems such as Coil-system, off-board power electronics system, on-board power electronics system and communication link between off-board and on-board sub-systems. Fig. 1 shows a generic schematic of a wireless charger power line.

The development of a Wireless Charger for light Electric vehicles is a NaMPET funded project and is jointly developed by VNIT Nagpur and C-DAC Trivandrum.

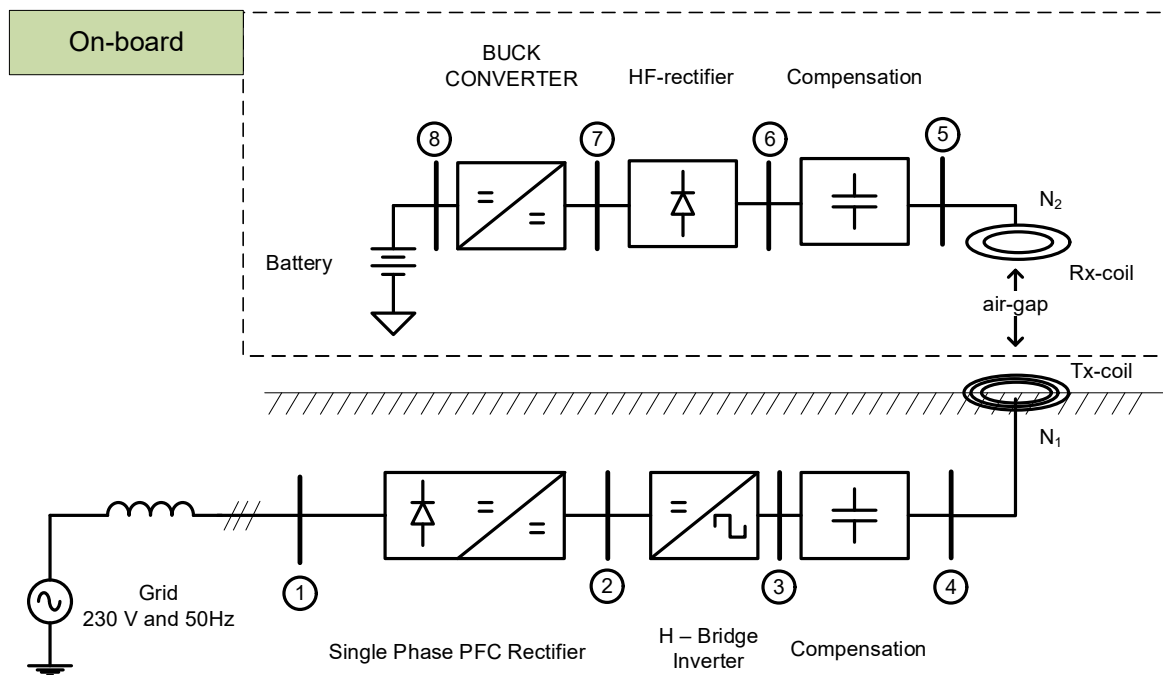

Fig.1. Generic schematic of a wireless charger power line

4. Know how involved in the ToT:

1. PFC Rectifier technique to increase PF up to 0.98 and reduction in THD of input current below 5% of rectifier.
2. Operation of H-bridge inverter at higher frequency
3. Compensation circuit design in both transmitting and receiving side.
4. Design of coil

5. High frequency rectifier and capacitor filter design in receiving side.
6. Buck converter design to charge EV battery in CC-CV mode.

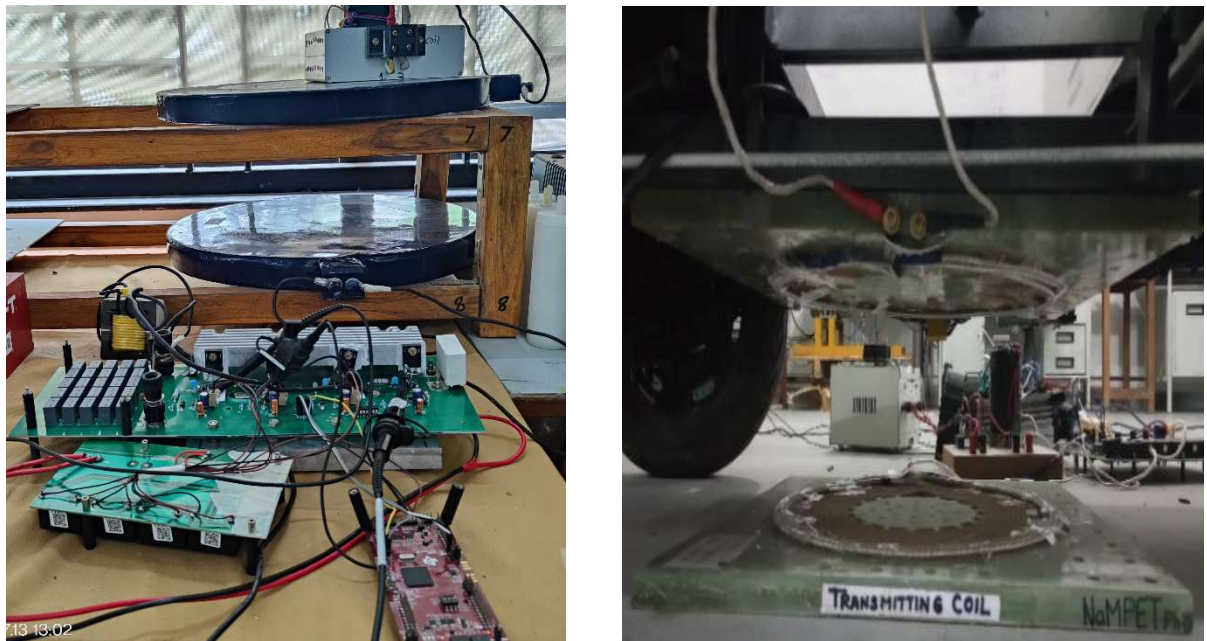

Fig.2. Wireless charger system

5. Advantages of Wireless Charger:

- 1) No physical connection
 - a) No need of any electrical connection to connect EV with Grid
- 2) Electrical isolation
 - a) In power electronics converter no need to provide electrical isolation
 - b) Each coil provides electrical isolation between grid and EV
- 3) Modularity
 - a) Coil and other semiconductor components can also be placed near to each other.
 - b) Semiconductor component can be placed below to coil in transmitting side.
 - c) Semiconductor component can be placed above to coil in transmitting side.
- 4) Ease of manufacturability and cost reduction
 - a) Ease of PCB automation techniques can be adapted for mass production.
 - b) In Coil manufacturing also automation techniques can be used

6. Applications of Wireless Charger based systems:

As the wireless charger energy transfer from off-board AC or DC supply system to on-board batteries without any physical connection

A few of the PE systems which can be technically enhanced by wireless power transfer technology are listed below.

- 1) Electric Vehicle chargers

- 2) Automated Scheduled Charging of Electric Vehicles in Charging Station and public places such as parking, hotels etc through the concept of central charger
- 3) Drone charging for Autonomous Surveillance drones
- 4) Wireless power transfer for medical Implants
- 5) In-Air Wireless Charging of Drones and Fighter Planes like Air refueling.
- 6) Contactless electrical connection
- 7) Aerospace application (with satellite launch vehicles for contact less power supply to pay-loads)

7. Invitation for Expression of Interest

- 7.1. C-DAC invites “Expression of Interest” (EOI) in the format given in Annexure-1 (Part A & Part B). Companies can become ToT partner of C-DAC based on the information furnished in Annexure – I, subject to the assessment by the C-DAC.
- 7.2. Expression of Interest (EOI) also seeks from interested industry vendors to offer the best price for onetime ToT licensee subscription cost for the listed items.
- 7.3. The minimum base price for the ToT of **Wireless Charger for light electric vehicles** has been finalised by the ToT Committee (constituted by the Competent Authority) as per the terms of reference finalised by C-DAC. The vendor offering the highest price in a category shall be designated as H1 price. If the value of H1 price is more than the minimum base price finalised by C-DAC, then H1 bid shall be considered as the final price under that category. If the value of H1 bid is less than the minimum base price finalised by C-DAC, then the base price finalised by C-DAC shall be considered as the final price under that category. Committee will finalize this price based on the bids received and considering the market potential.
- 7.4. This invitation of EOI will be open till 10th Nov 2024. No companies can offer the price for this product in this EOI invitation after the EOI closure date. The financial bids received till the last date of EOI shall only be evaluated to arrive at the final cost of ToT license.
- 7.5. If there are no respondents to the EOI, the base cost already finalised by the ToT Committee shall be fixed as the license cost for the ToT.
- 7.6. Interested companies may submit the expression of interest (see section 5.0 and section 6.0)
- 7.7. The EOI bids received from the vendors shall be evaluated to discover the best H1 bid.
- 7.8. After the evaluation, the cost finalised by C-DAC for the ToT will be informed to all the bidders who have participated in the EOI.
- 7.9. After the evaluation, the draft ToT agreement will be shared with the eligible company. If the company agree to the terms and conditions of the agreement, the agreement can be signed after payment of the onetime ToT license fee as stipulated in the payment terms for that product. The company then become eligible for obtaining the knowhow of ‘**Wireless Charger for light electric vehicles**’ for the prescribed period from C-DAC.
- 7.10. Once price is finalised EOI (EOI-2) will again be floated for a specific period inviting. Other companies who have not participated in the initial EOI can submit their expression of interest for becoming TOT partners, based on terms and conditions (including price) already

finalized based on initial EOI. The companies who have participated in EOI-1 need not participate in EOI-2.

- 7.11. Participation in this EOI does not guarantee any association with C-DAC, unless the agreement is signed.
- 7.12. The technology is offered on non-exclusive basis.
- 7.13. The submission of the EOI shall include all such documents that are specified herein to prove the authenticity of their offer and any claim made therein. All cost and expenses associated with submission of EOI shall be borne by the bidder while submitting the EOI and C-DAC shall have no liability, in any manner in this regard, or if it decides to terminate the process of short listing for any reason whatsoever.
- 7.14. C-DAC reserves the right of rejecting any offer without assigning reasons.
- 7.15. There is neither a business guarantee nor any commitment for funding support from C-DAC to the selected ToT partner.

8. Who can Apply

- 8.1. Any Indian Company or Start Ups willing to acquire ToT licenses, manufacture, market, sell and deploy **‘Wireless Charger for light electric vehicles** can apply.

9. How to Apply

Interested companies may send expression of interest by filling the template as per Annexure – I, II, and III along with supporting documents to

Section Head, Technology Promotion Centre

Centre for Development of Advanced Computing (C-DAC)

Vellayambalam, Thiruvananthapuram, Kerala, India, 695033

Phone: 098470 69184/04712723333(450) Fax: 0471 2723456

Email: tpc@cdac.in Website: www.cdac.in

10. ToT Agreement

- 10.1. The ToT partner is selected based on the expression of interest submitted by interested companies.
- 10.2. If selected, the company shall pay onetime ToT license subscription fee and sign the ToT agreement to become ToT partner of C-DAC. One time ToT license subscription fee finalised by C-DAC shall be informed to all the bidders who have participated in the EOI.
- 10.3. C-DAC shall sign the technology transfer agreement with the company on receiving the one time ToT fee.
- 10.4. The license will be granted on Non-Exclusive basis.
- 10.5. Provision for instalment payment for ToT fee shall be given.

ToT fee shall in two instalments:

First instalment of 50% plus applicable taxes shall be paid upon signing the agreement. The design documents shall we provided only after the first instalment.

A balance of 50% plus applicable taxes shall be paid as second instalment. The fabrication document and layout methodology shall be delivered during this instalment. Handover of ToT deliverables as last instalment.

However, only after making the entire ToT payment would the ToT partner shall have the right to produce, market, distribute, and deploy "**Wireless Charger for light electric vehicles**"

- 10.6. In addition, there shall be a royalty of 10% for all the '**Wireless Charger for light electric vehicles**' sold or deployed by the ToT partner for a period of 10 years.
- 10.7. No ToT partner will be allowed to quote for '**Wireless Charger for light electric vehicles** unless he enters into an agreement and pays the ToT fees. The ToT fees are non-refundable. In case any party offer /quotes the rates without an agreement with C-DAC, C-DAC will not honour the rates/ will not give the ToT to such party.

11. Validity & Renewal of TOT agreement

- 11.1. For continued support beyond 3 years the partner shall be required to renew the ToT agreement by paying the renewal charges plus applicable taxes before the expiry of valid ToT license, which will be valid for a further extended period of two years.
- 11.2. The renewal charges shall be informed while signing the TOT agreement.
- 11.3. If the renewal is initiated after the stipulated period, a fresh TOT agreement needs to be signed by the company based on the EOI conditions prevailing at that time.
- 11.4. The partner should have a valid ToT subscription license for providing any technical support on the ToT deliverables made by C-DAC.
- 11.5. After five years (from the date of signing the ToT agreement) a new TOT agreement is to be signed by the company based on the EOI conditions prevailing at that time.
- 11.6. Any customisation requirements of the ToT partner shall be entertained by C-DAC only if a valid ToT subscription exists. Such customisations shall be undertaken by C-DAC at cost basis on mutually agreed terms and conditions.

12. Deliverables

- 12.1. On payment of onetime license fee and signing of ToT agreement, the following items shall be provided by C-DAC to the TOT partner for production, product marketing support and PoC demonstration.

The deliverables will be

- i. ToT Partnership certificate
- ii. Technical Manual
 - a. Introductory technical document and preliminary training
 - b. Design details of Wireless charger components
 - c. Winding architectures for the reduction in d.c. resistance
 - d. Winding architectures for the reduction in a.c. resistance

- e. Winding architectures to reduce the stray capacitance
- f. Winding architectures to control the leakage inductance
- g. Winding architecture for the high voltage magnetic components
- h. Testing methodology of wireless charger components and training
- i. Detailed design document and hands-on training for the fabrication of one inductor and one transformer of specifications supplied by ToT partner
- j. After the fabrication of magnetic components by ToT partner, its performance will be evaluated to validate the specification
- iii. Sourcing details
- iv. PCB design with Gerber files
- v. Test Plan and Procedure

13. Training for TOT Partners

- 13.1. C-DAC and VNIT shall arrange the following training for the TOT partner at VNIT Nagpur , for which the travel, boarding, and lodging expenses of the trainee(s) during the period of training shall be borne by the ToT partner
- 13.2. The training will be conducted at VNIT Nagpur premises.
- 13.3. The travel and boarding and lodging expenses of the trainee(s) during the period of training shall be borne by the ToT partner.
- 13.4. Additional training at the premises of ToT Partner or at the client location shall be done on payment basis. For training requested outside C-DAC(T) / VNIT premises, air travel, boarding and lodging charges of C-DAC trainers shall be borne by the ToT partner. C-DAC will charge manpower as per C-DAC /VNIT rules prevailing at the time of training for outstation training. For such outstation trainings nomination of trainers and period of stay at the designated training location will be decided by C-DAC(T) VNIT on mutual consultation, depending on the type of training requested.
- 13.5. Additional training may also be given by C-DAC/VNIT either at the premises of C-DAC(T) or at the location identified by the ToT partner on payment basis at mutually agreed terms and conditions.

14. Field implementation support

- 14.1. C-DAC(T)/VNIT shall provide remote support to the ToT partner for design and testing of **Wireless Charger for light electric vehicles** during the ToT period on case-to-case basis upon mutually agreed terms and conditions.
- 14.2. If any onsite support is requested by the ToT partner, C-DAC/VNIT shall support on mutually agreed terms and conditions.
- 14.3. For onsite support outside C-DAC/VNIT premises travel, boarding and lodging charges of C-DAC(T)/VNIT officials shall be borne by the ToT partner. C-DAC/VNIT shall also charge manpower as per C-DAC/VNIT rules prevailing at the time of support request for outstation support. Size of the C-DAC(T)/VNIT team and period of stay for outstation

support shall be decided by C-DAC(T)/VNIT on mutual consultation, depending on the type of support requested.

15. Direct deployment by C-DAC and VNIT

- 15.1. C-DAC/VNIT reserves the right to deploy **Wireless Charger for light electric vehicles** directly to customers on orders for implementation awarded directly by the end user.
- 15.2. If C-DAC and VNIT is deploying **Wireless Charger for light electric vehicles** directly, then the cost at which C-DAC and VNIT will be offering the solution to the end user will be decided by factors, such as inductance value, leakage inductance, current rating, flux density, size, efficiency, turn ratio, etc. as per the specification of end user. This decided cost includes only the cost of basic system and does not include installation, deployment, training, support etc.

16. Maximum List Price /GeM Price

The Maximum List Price/GeM price of 1.5 Kw **Wireless Charger for light electric vehicles** listed in GEM, by C-DAC and VNIT will be decided by factors, such as inductance value, leakage inductance, current rating, flux density, size, efficiency, turn ratio, etc. as per the specification specified, excluding tax. This cost includes only the cost of basic system and does not include installation, deployment, training, support etc. However, the TOT partner can fix their selling price.

For any queries please contact:

Section Head (Technology Promotion Centre)
Vellayambalam, C-DAC, Thiruvananthapuram
Contact: 098470 69184/04712723333(450),
email: tpc@cdac.in

Annexure –I (Part-A)

Company Profile of the bidder

A.	Company Profile
1.	Name of the Organization: Website:
2.	Name of the Contact Person: Address: Mobile: Landline: Fax: E-Mail:
3.	Year of Incorporation:
4.	Type of Organization a. Public Sector/ Limited/Private Limited/ Partnership/Proprietary/ Society/ Any other b. Whether 'Foreign Equity Participation (Please give name of foreign equity participant and percentage thereof) c. Names of Directors of the Board/ Proprietors d. Name and address of NRI(s), if any
5.	Category of the firm: Large/Medium/Small scale unit / Others
6.	Address of the Registered Office: (Include Certificate of Registration)
7.	Number of Offices with addresses (Excluding Registered Office): India, Abroad:.....
8.	Certificate of registration as a manufacturing unit
9.	Permanent Account Number
10.	GST Reg. No.
11.	ISO or any equivalent Certification

Annexure – I (Part B)**Technical Collaborations of the bidder**

B.	ESSENTIAL REQUIREMENTS
1.	The organization must be a reputed firm/company/SME/startup/R&D company incorporated in India.
2.	The turnover is to be supported by financial statements of accounts/ Annual reports duly certified by a Chartered accountant/ Balancesheets of last 3 years/ Income tax returns for the last 3 years period.
3.	Company profile, giving details of current activities and management/ personnel structure including evidence of incorporation. The company should be registered and ISO orequivalent certified.
4.	Details of absorption of technology for a product/knowhow that has been taken up on production scale in the past may also be given
5.	The manpower strength (Technical:Mechanical, Electrical, Electronics, Software & Non-Technical etc.) at various levels to be furnished Technical: a. B.E./ B.Tech / M.Tech / PhD b. DIPLOMA c. SKILLED TECHNICIANS d. UNSKILLED
6.	The list of machine tools /equipment/software/facilities available related with work to be furnished.
7.	The in-house technological expertise available to be furnished
8.	The list of equipment available for inspection and quality control to be furnished.
9.	The industry should have adequate space for undertaking this work. Available space - Covered & Open and location details to be furnished.
10.	List of products/technologies worked with as regular activity in last three years. Give the list of products/technologies with general specifications and the customers.
11.	List of PSUs/Govt..customers – with contact details (Address,Telephone no., Contact Person)
12.	The details of sales, marketing and maintenance network to be furnished
13.	The list of technical collaborators for various ongoing products may be furnished
14.	The bidder shall provide details of the sub-vendors in case they propose to employ for Part-work.
C.	Expression of Interest: Spell out the extent of interest and envisaged market potential

I hereby declare that the above information is true to the best of my knowledge.

Signature with Name & Seal:

Place:

Date:

Annexure-II Financial Bid Format

(To be submitted in sealed envelope / by mail)

Price bid One Time TOT License subscription cost

Sl. No.	Product	Company status	ToT Partnership licence cost for 3 years in Rs. (excluding taxes)	ToT Partnership licence cost for the extended period (4 th & 5 th year)in Rs. (excluding taxes)
1	1.5Kw Wireless Charger for light electric vehicles			



Wireless Charger for Light Electric Vehicle





◆ **NaMPET Initiative**

◆ **Ecofriendly**

◆ **Designed in India**

SPECIFICATIONS

Input	Output
<ul style="list-style-type: none"> ⊙ Single phase 230V, 50Hz ⊙ Power factor more than 0.96 ⊙ Operating frequency : 88kHz 	<ul style="list-style-type: none"> ⊙ Charging current : 30A @48V ⊙ Charging time : approx. 3 hours ⊙ Air gap separation 12.5cm ⊙ Coil misalignment up to 50%
<div style="background-color: #c0ffc0; padding: 5px; margin-bottom: 5px;">Protection</div> <ul style="list-style-type: none"> ⊙ Short circuit and open circuit protection at charger output ⊙ System is thermally stable 	<div style="background-color: #c0ffc0; padding: 5px; margin-bottom: 5px;">Overall Efficiency & TRLs</div> <ul style="list-style-type: none"> ⊙ Overall efficiency grid point to battery 89.4% (7.5cm coil separation); 84% (for 12.5cm); 78% (for 10cm) ⊙ Capability (TRL – 8)



Visvesvaraya National Institute of Technology,
South Ambazari Road, Nagpur, Maharashtra.
Website : <https://vnit.ac.in>



NaMPET
National Mission on
Power Electronics Technology

Centre for Development of Advanced Computing
P.B.NO:6520, Vellayambalam, Thiruvananthapuram - 695033, Kerala (India)
Phone: +91 9846 141 021 email: peg@cdac.in





APPLICATIONS

- ⊙ This Wireless Charger can be used to charge Light Electric Vehicles.
- ⊙ Autonomous Drone Charging
- ⊙ Implant Biomedical Devices Charging
- ⊙ Space Vehicle Charging





Visvesvaraya National Institute of Technology,
South Ambazari Road, Nagpur, Maharashtra.
Website : <https://vnit.ac.in>



NaMPET
National Mission on
Power Electronics Technology

Centre for Development of Advanced Computing
P.B.NO:6520, Vellayambalam, Thiruvananthapuram - 695033, Kerala (India)
Phone: +91 9846 141 021 email: peg@cdac.in